

Technical Information System component WOLFF Undercarriage

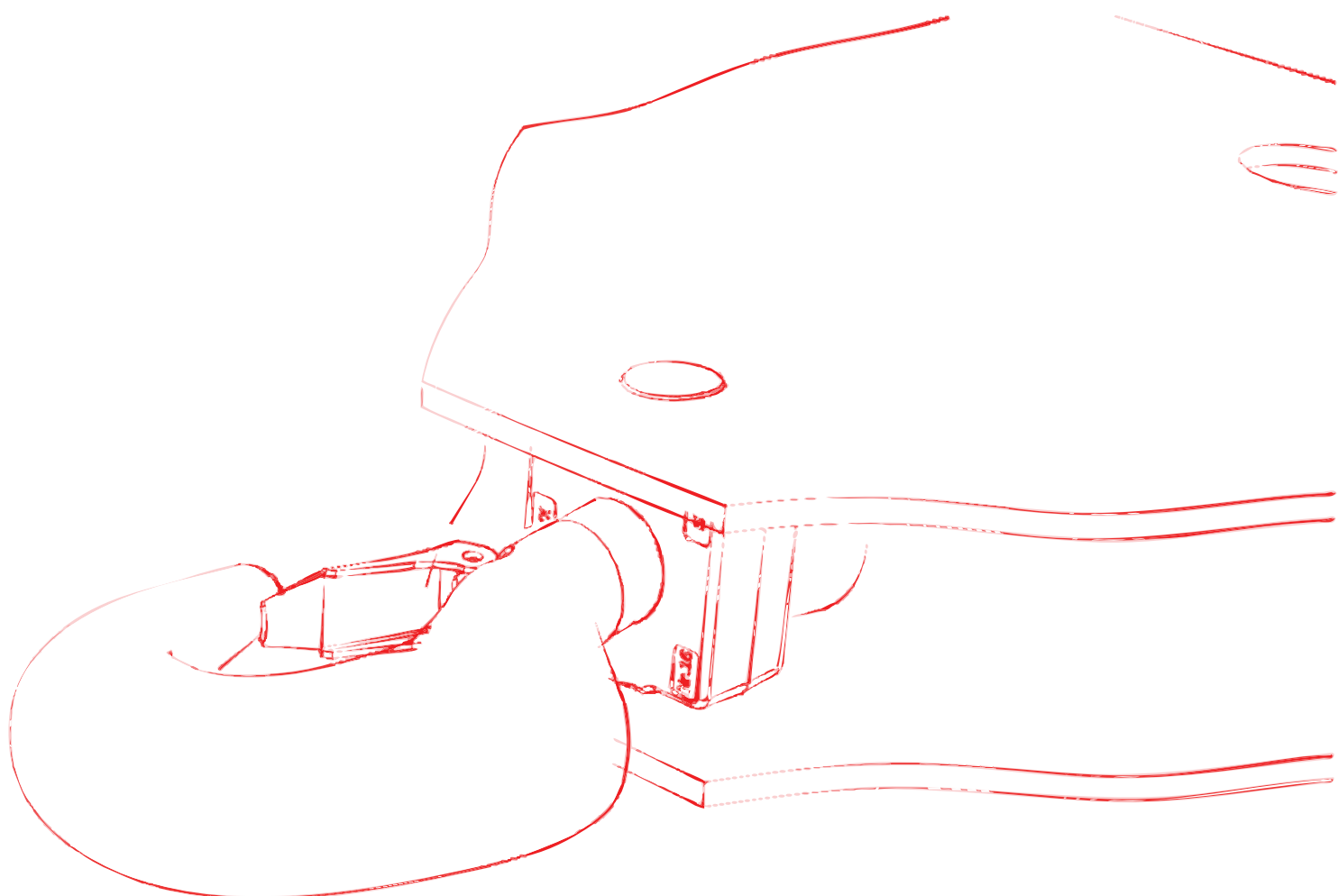

Original operating manual

German

English



Published by

WOLFFKRAN GmbH

Austraße 72

74076 Heilbronn

Germany

Phone +49 7131 9815 0

Fax +49 7131 9815 355

www.wolffkran.com

info@wolffkran.de

Copyright

This documentation including all of its subsections is protected by copyright laws.

Any type of use or modification outside of the stringent limits of the copyright laws without permission of WOLFFKRAN GmbH is prohibited and subject to penalties.

This applies particularly for copying, translation, microfilming and storage and processing in electronic systems.

At the time of printing, the information, data, illustrations and notes comprised in this manual were up-to-date.

Subject to change of design, error and typos.

Table of contents

1 Undercarriage UW 4120	1 / 1
--------------------------------------	--------------

This page was intentionally left blank!

1 Undercarriage UW 4120

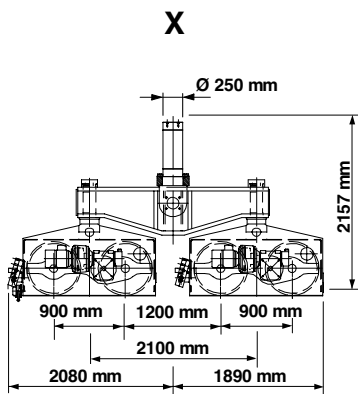
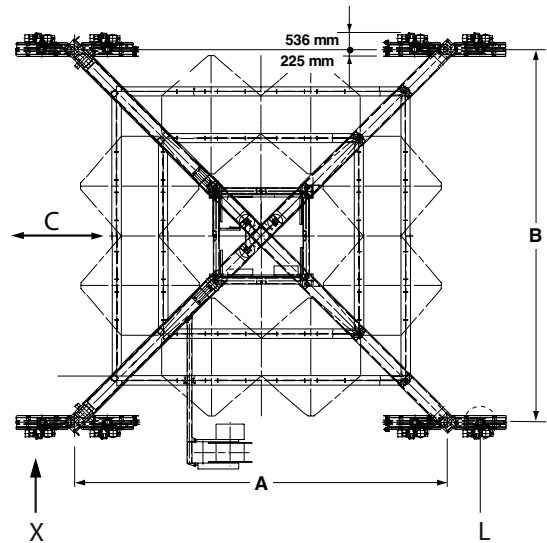
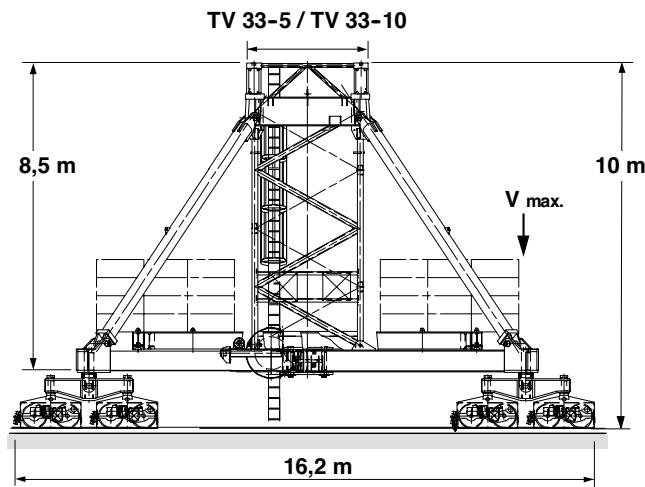

Undercarriage UW 4120

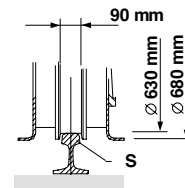

X	View X	L	Detail L
C	Direction of travel	S	Rail

Rail gauge A	12.00 m
Wheelbase B	12.00 m
Rail material	S 64 DIN 5902
Crane traversing speed	30 m/min
Accumulated motor power	8 x 5.5 kW
max. permitted corner load	2500 kN
Total weight of undercarriage (without ballast)	74900 kg

The undercarriage represents an independent module for applications with a WOLFF slewing tower crane system.

For information pertaining to application options, refer to the manual of the corresponding WOLFF slewing tower crane (tower combination, central ballast block / corner load tables).

This page was intentionally left blank!

This page was intentionally left blank!

WOLFFKRAN Group

Headquarter international:

WOLFFKRAN AG

Hinterbergstrasse 17

CH-6330 Cham

Switzerland

Phone +41 41 766 85 00

Fax +41 41 766 85 99

info@wolffkran.com

Manufacturing:

WOLFFKRAN GmbH

Austraße 72

D-74076 Heilbronn

Germany

Phone + 49 7131 9815 0

Fax + 49 7131 9815 355

info@wolffkran.de

WOLFFKRAN Werk Brandenburg GmbH

Frederik-Ipsen-Straße 5

D-15926 Luckau OT Alverno

Germany

Phone + 49 35456 674 0

Fax + 49 35456 674 200

info@wolffkran.de